



Signal Isolator and Converter (2-Wire)

SCX

User's Manual

All product names are registered trademarks of their respective companies.

Customer Support

Moore Industries is recognized as the industry leader in delivering top quality to its customers in products and services. We perform a sequence of stringent quality assurance checks on every unit we ship. If any Moore Industries product fails to perform up to rated specifications, call us for help. Our highly skilled staff of trained technicians and engineers pride themselves on their ability to provide timely, accurate, and practical answers to your process instrumentation questions. Our headquarters and other facilities phone numbers are listed below.

There are several pieces of information that can be gathered before you call the factory that will help our staff get the answers you need in the shortest time possible. For fastest service, gather the complete model and serial number(s) of the problem unit(s) and the job number of the original sale.

Locations

World Headquarters

16650 Schoenborn Street
North Hills, California
91343-6196, **U.S.A.**
Tel: (818) 894-7111
Fax: (818) 891-2816
E-mail: info@miinet.com
TOLL FREE: 1-800-999-2900
www.miinet.com

Europe

1 Lloyds Court, Manor Royal,
Crawley
W. Sussex RH10-9QU
United Kingdom
Tel: 01293 514488
Fax: 01293 536852
FREE PHONE: 0800 525107
sales@mooreind.com

Australia

Sydney, NSW
3/1 Resolution Drive
Caringbah, New South Wales 2229
Australia
Tel: (02) 8536-7200
Fax: (02) 9525-7296
sales@mooreind.com.au

China

Room 402, No. 57,
Lane 651, Xipu Road,
Xinqiao Town, Songjiang District,
Shanghai, 201612, P. R. China
Tel: 86-21 62491499
Fax: 86-21 62490635
E-mail: sales@mooreind.sh.cn

BeNeLux

Guido Gezellestraat 106
BE-2630 Aartselaar
Belgium
Tel: 03/448.10.18
Fax: 03/440.17.97
info@mooreind.eu

Perth, WA
6/46 Angove Street
North Perth, Western Australia 6006
Australia
Tel: (08) 9228-4435
Fax: (08) 9228-4436
sales@mooreind.com.au



www.miinet.com

Table of Contents Introduction

Description	4
Calibration	6
Installation	8
Recommended Ground Wiring Practices	9
CE Conformity	9
Installation in Hazardous Locations	9
Specific Conditions of Use	10
Maintenance	13

48^{HR.} DELIVERY



United States/Canada
TOLLFREE
1-800-999-2900

16650 Schoenborn Street
Sepulveda, California 91343, U.S.A.
Tel: (818) 894-7111 • Tlx: 65-1322
FAX: (818) 891-2816
CONNECT (MacNet): MIISEPULVEDA

United Kingdom
FREEPHONE
0800 525 107

1 Lloyds Court, Manor Royal, Crawley
W. Sussex RH10-2QU, United Kingdom
Tel: 0293 514488 • Tlx: 87667
FAX: 0293 536852

Australia
TOLLFREE
008251928

3/18 Resolution Drive, Caringbah
New South Wales 2229, Australia
Tel: (02) 525-9177 • Tlx: 790-75914
FAX: (02) 525-7296

Ask for the STAR Center

Moore Industries' STAR* Center has a wide variety of quality instrumentation in stock and ready to ship.

- Signal Transmitters
- Temperature Transmitters
- P/I and I/P Converters
- Isolators and Converters
- Indicators and Displays
- Alarm Trips
- Integrators and Totalizers
- Power Transducers
- Instrument Power Supplies
- Racks, Rails and Enclosures

Most instruments can be customized to meet your needs. Even then, you'll never have to wait more than a few days.

Moore Industries

STAR
CENTER

* Support, Technical Assistance, and Repair (our Quick-Ship Facility)

Introduction

Moore Industries' Signal Current Isolator (SCX) is a process instrument that accepts a process variable current input and provides an isolated current output.

This manual contains descriptive, calibration, and installation information for the SCX. Notes are presented in this manual to help you avoid minor inconveniences while calibrating or installing this instrument.

Description

The SCX accepts a 4-20 or 10-50 milliamper (mA) input and outputs a proportional, isolated process variable signal of the same value. Units with 10-50 mA inputs can be factory-configured to output 4-20 mA (not with ECD Housings). Units configured with 4-20 mA inputs have 4-20 mA outputs only. The input and output are factory configured to user specifications.

Power requirements for the SCX vary depending on the combined input/output configuration of the unit. Table 1 listed the voltage drops (requirements) considerations for the SCX.

The SCX has no visual indicators, but does have one adjustment; the TRIM potentiometer (pot). The TRIM pot is located on the front panel and is used to adjust the output signal for a precise span value.

The SCX is available in three basic housing styles; the hockey-puck (HP), DIN-style, and economy DIN-style (ECD). Functionally they are identical. The housing style you select should be based on the application and the environment in which the unit is to be used.

Table 1 contains the operational and performance specifications of the SCX.

Options

The SCX is available with the following options:

RF Option — RFI and EMI protection to 50 V/m – abc -0.1% of full-scale when tested according to SAMA standard PMC 33.1 (not available for ECD Housings).

RTB Option — Removable terminal block for DIN-style units only.

WTD Option — Water-tight enclosure for ECD housed units meeting NEMA 4 and SAA Type N (IP65) requirements.

For information on availability of other SCX options, contact your local Moore Industries' Sales Representative.

Serial/Model Number. Moore Industries uses a serial number-based tracking system to maintain historical records on each individual product that we sell or service. The model number contains important configuration information about the product to which it corresponds. Together, the serial and model numbers provide the factory, and the user, with information regarding the unit's history and functional configuration.

If service information is required, you must provide the factory with the unit's serial number. Providing the model number is also important when technical assistance is required. The serial and model numbers for PC units is etched into a stainless steel tag on the front of the unit. For DIN-style and ECD units, these numbers are printed on a label and affixed to the side of each unit.

The model number contains information about the configuration of the unit as it was shipped from the factory. The following model number example identifies the significance of each field of the SCX model number.

Table 1. SCX Operational and Performance Specifications

Charateristic	Specifications
Input	4-20 mA , into 275 Ω 10-50 mA , into 150 Ω
Output	4-20 mA , into 0-250 Ω 10-50 mA , into 0-100 Ω
Power	Supplied as input, loop excitation: 5.5 V loop power , for 4-20 mA input and output 8.5 V loop power , for 10-50 mA input and output 4.5 V loop power , for 10-50 mA input and 4-20 mA output (Power requirements listed are the voltage drops caused by the SCX alone.)
Controls	Multiturn potentiometer, front panel Trim: Adjusts output to $\pm 1\%$ of span accuracy
Performance	Accuracy: $\pm 0.075\%$ of span Isolation: Input and output are transformer isolated to 500 Vrms, no dc connections Temperature Affect: $\pm 0.018\%/^{\circ}\text{C}$ ($\pm 0.01\%/^{\circ}\text{F}$) per degree change; $\pm 0.005\%$ per degree gain change
Environmental Ratings	Ambient Operating Temperature: -29 to 82°C (-20 to 180°F)
NOTE: Refer to the Installation Section of this manual for the unit's outline dimensions.	

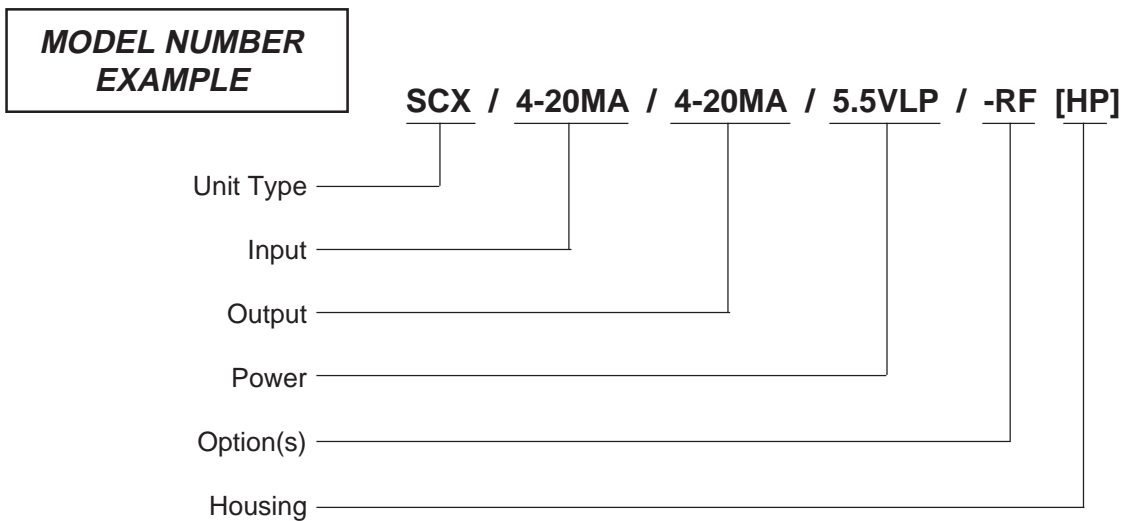

Calibration

Every SCX is calibrated and tested at the factory prior to shipment. Before placing an SCX into service, you should set it up for a bench check and verify that it responds to known inputs in a predictable manner. A bench check will indicate if the SCX is ready to be placed into service or if it needs to be re-calibrated. To bench check and calibrate an SCX properly, you must use test equipment that allows you to vary the input and monitor the output. The equipment and setup requirements are described in the Calibration Setup subsection later in this section.

SCX Controls

The SCX has one control; the Trim pot. This potentiometer is located on the front panel (all housing styles) and is labeled "TRIM". This adjustment changes the gain of the output span. This single adjustment varies the zero- and 100-percent output values equally so that you can adjust the signal to have the same amount of offset at both extremes. With the Trim adjustment you can set the 16 mA span for 4-20 mA outputs with very high precision. The same is true for the 40 mA span of the 10-50 mA outputs.

Calibration Setup

Since the SCX has no visual indicators, its operational performance must be verified with calibration equipment. The equipment required to bench check and calibrate the SCX is listed in table 2. The accuracy of the equipment used is very important. If uncalibrated test equipment is used, the input you apply and output readings you observe will be unreliable, and the actual performance of the SCX unpredictable.

Although the SCX can be calibrated in its installation location, typically it is easier to work with the calibration equipment in a laboratory setting (e.g., a technicians workbench).

Figure 1 illustrates the hookup requirements for bench check and calibration of the SCX. The terminal designations for each connection are clearly marked on the front panel of each unit. The SCX uses four terminals; +IN and -IN for the input signal and +OUT and -OUT for the isolated output signal.

All housing styles use a compression-screw principle to make individual wire connections. HP and ECD housed units provide wire access through the top and bottom of the terminal locations with compression screws accessed at the front of the unit. For standard DIN-style units the wire and screw access are both on the same plane (i.e., the front surface) of the unit.

Table 2. SCX Calibration Equipment

Equipment	Characteristics
Adjustable Current Source	Capable of simulating specified input range (4-20 or 10-50 mA) and voltage requirements (see table 1)
Voltmeter & Load Resistor	Voltmeter, accuracy of 0.05% or better; Load resistor, 250 Ω for 4-20 mA output, 100 Ω for 10-50 mA output, tolerance of $\pm 0.02\%$
Milliammeter	Accuracy of 0.05% or better
Screwdriver	Slotted-tip, head width no greater than 2.54 mm (0.1 inch)

SCX

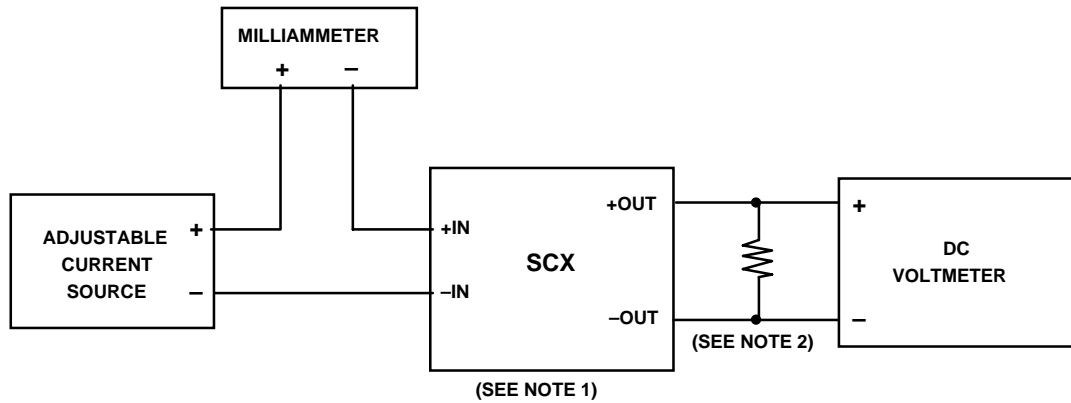

- NOTES: 1. Check unit's model number for input and output configuration.
 2. For a 1-5 Vdc reading, use a 250 resistor for 4-20 mA outputs or a 100 resistor for 10-50 mA output.

Figure 1. SCX Calibration Hookup

Calibration Procedure

Before beginning this procedure, check the model number of the unit to be calibrated to verify the power requirement of the unit and what the input and output are configured for. The following procedure is suitable for all SCX's.

Refer to table 2 for a list of calibration equipment and use figure 1 for hookup requirements.

1. Connect SCX and calibration equipment as shown in figure 1.
2. Apply power and allow SCX to warm-up for 5 minutes.
3. Set adjustable input source for median input based on input configuration (12 mA for 4-20 mA input; 30 mA for 10-50 mA input).
4. Monitor output with voltmeter to verify proportional output reading is present (3 Vdc).

NOTE

If your unit is configured for 10-50 mA input and 4-20 mA output, an input of 30 mA should produce an output reading 12 mA (3 Vdc).

5. Adjust TRIM pot, as required, to bring the median output reading to match the (appropriate) median input.
6. Set adjustable input source for zero-percent input as stated in model number.
7. Verify zero-percent output (1 Vdc, ± 3 mV) corresponds to zero-percent input.
8. Set adjustable input source for 100-percent input as stated in model number.
9. Verify 100-percent output (5 Vdc, ± 3 mV) corresponds to 100-percent input.
10. If zero- or 100-percent output reading do not correspond to appropriate inputs, repeats steps 3 through 9.
11. When output readings are stable and consistent, remove power and disconnect calibration equipment. Calibration is complete.

If you have difficulty performing the calibration procedure, contact Moore Industries' Customer Service Department for assistance.

Installation

Installing the SCX consists of physically mounting the unit and completing the necessary electrical connections. Before installing the SCX, you should check its model number and bench check it to ensure it is properly configured for the intended application.

Installation is generally made easier by mounting the unit before making the electrical connections.

Mounting the SCX

The SCX is available in three basic housing styles. Regardless of the housing style chosen, mounting the SCX in an area free of excessive dust, moisture, or corrosive elements will prolong the life of the unit.

The HP Housing. The HP Housing is designed to mount inside explosion-proof enclosures. Spring clips on the basic HP Housing are used to hold the unit in the base of the enclosure. By squeezing the

ends of the spring clips toward one another, the unit can be positioned in the base. When released, the spring clips apply adequate outward pressure to hold the HP unit in the enclosure. If the basic HP Housing is equipped with flange plates (FL Housing), it can be mounted on flat surfaces or relay tracks. Figure 2 is an outline dimension drawing of the HP Housing. The spring clips have no dimensional significance so they are not shown, but the flange plates do (see figure 2).

The DIN-style Housing. The DIN-style Housing is designed to mount directly on standard G-type (EN50035) or Top-hat (EN50022) DIN rails. At the rear of this unit are the lips and grooves for mounting on a rail. This unit is mounted by positioning it so that the upper portion of the DIN-rail mating elements hook either under or over (depending on the rail type) the top of the rail, then, rotate the front of the unit downward. Figure 3 is an outline dimension drawing of the DIN-style SCX.

The ECD Housing. The ECD Housing is a plastic DIN-style housing. This housing mounts on the G-type and Top-hat DIN rails in the same manner as the DIN-style Housing. Figure 4 is an outline dimension drawing of the ECD Housing.

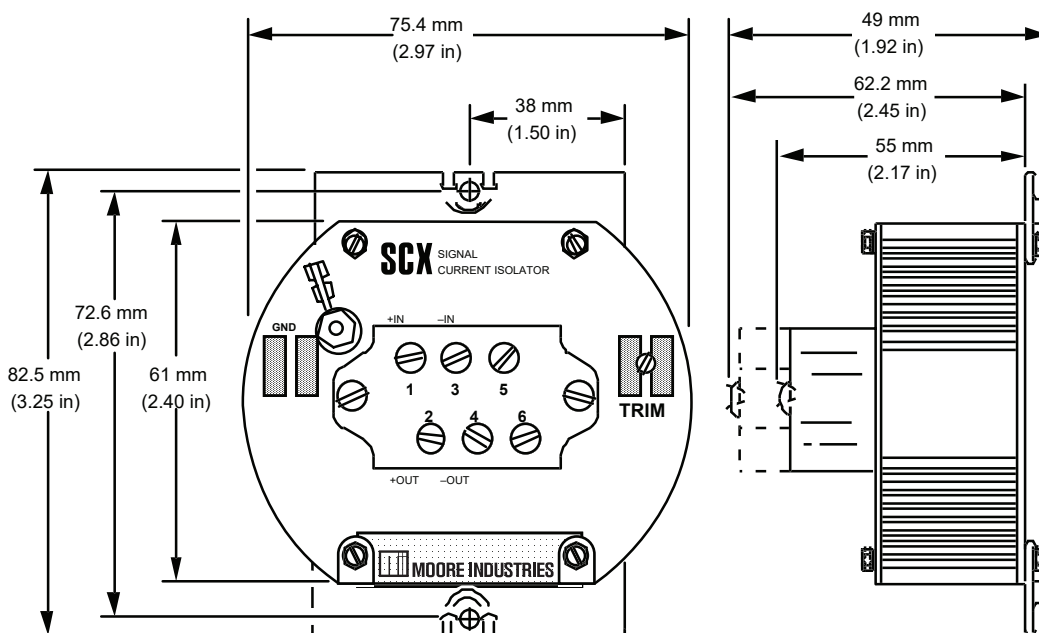

Figure 2. HP Housing Outline Dimensions (FL Housing shown)

Recommended Ground Wiring Practices

Moore Industries recommends the following ground wiring practices:

- Moore Industries product in a metal case or housing should be grounded.
- The protective earth conductor must be connected to a system safety earth ground before making other connections.
- All input signals to, and output signals from, Moore Industries' products should be wired using a shielded, twisted pair wiring technique. Shields should be connected to an earth or safety ground.
- For the best shielding, the shield should be run all the way from the signal source to the receiving device (see note below).
- The maximum length of unshielded input and output signal wiring should be 2 inches.

Note: *Some of Moore Industries' instruments can be classified as receivers (IPT2, IPX2, etc.) and some can be classified as transmitters (TRX, TRY, etc.) while some are both a receiver and a transmitter (SPA2, HIM, etc.). Hence, your shield ground connections should be appropriate for the type of signal line being shielded. The shield should be grounded at the receiver and not at the signal source.*

CE Conformity

Installation of Moore Industries' products that carry CE marking must adhere to the guidelines in the Recommended Ground Wiring Practices section in order to meet the requirements in EN 61326 and the relevant EMC directive.

Installation in Hazardous Locations

This section contains important information regarding installation of the MIX 2 wire 4 channel in Hazardous Area locations.

NOTE The SCX is suitable for Class I Division 2, Groups A-D or General Locations only.

WARNING Do not disconnect equipment when a flammable or combustible atmosphere is present.

AVERTISSEMENT Risque d'explosion. Ne pas débrancher tant que le circuit est sous tension, à moins qu'il ne s'agisse d'un emplacement non dangereux.

AVERTISSEMENT Risque d'explosion. La substitution de composants peut rendre ce matériel inacceptable pour les emplacements de Classe I, Division 2.

Specific Conditions of Use

The following instructions must be adhered to when the SCX is used in hazardous locations and potentially explosive atmospheres.

The SCX shall be installed in compliance with the enclosure, mounting, spacing and segregation requirements of the ultimate application.

cULus Installation

Nonincendive Applications

Class I, Division 2, Groups A-D

The SCX DIN shall be installed into an enclosure that utilizes a tool removable door or cover.

cFMus Installation

Nonincendive Applications

Class I, Division 2, Groups A-D

The SCX DIN shall be installed into an enclosure that utilizes a tool removable door or cover.

SCX

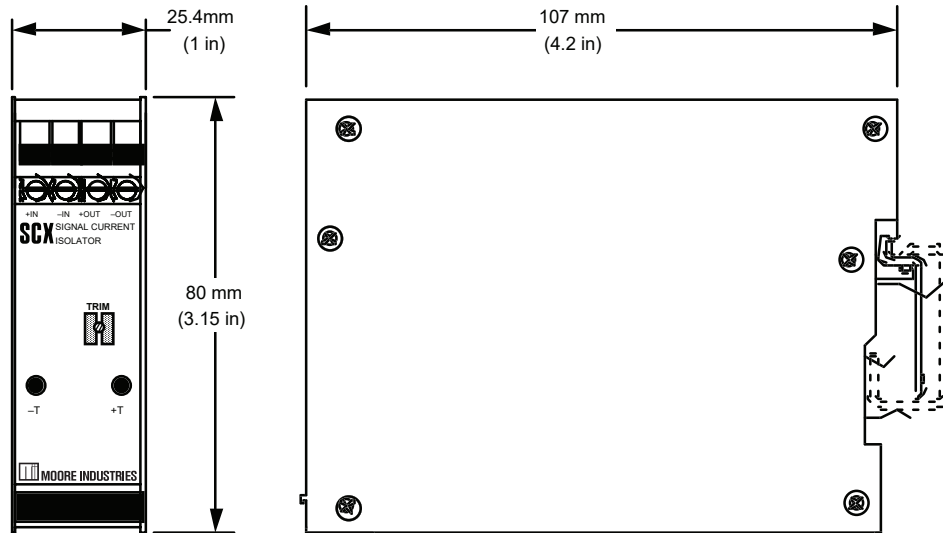

Figure 3. DIN-style Housing Outline Dimensions

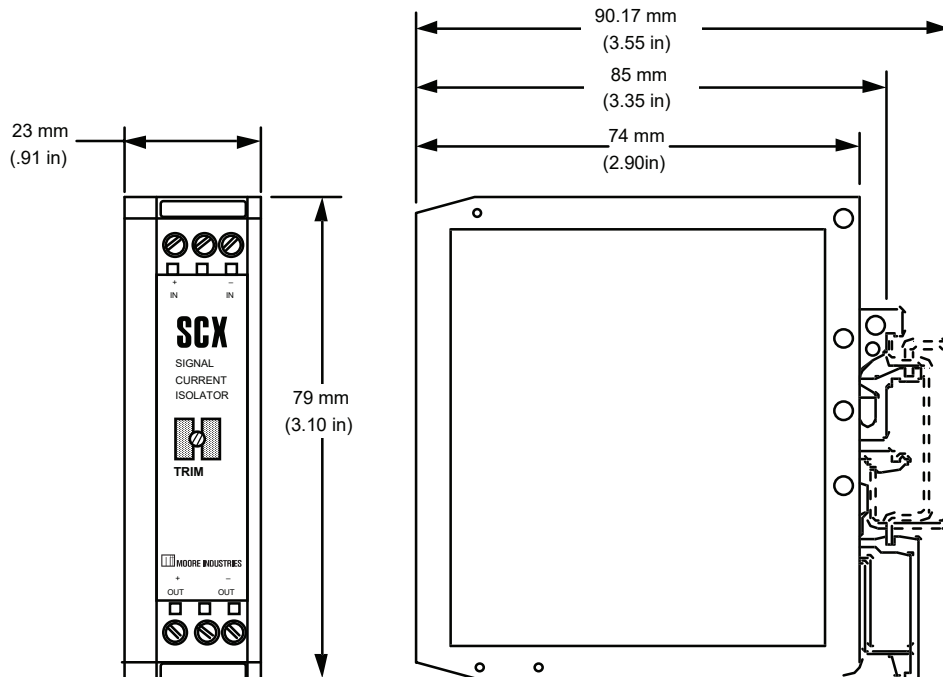

Figure 4. ECD Housing Outline Dimensions

Making the Electrical Connections

The electrical connections for the SCX are made to individual, compression-screw terminals. The +IN and -IN terminals are for the input signal. The +OUT and -OUT terminals are for the isolated output signal. Each of these terminals is clearly marked on the unit.

The ends of each termination wire should be striped appropriately 6.25 mm (0.25 inch) to expose bare conductor wire. If "stranded" signal wire is used, DO NOT apply solder to the termination area. For low-level signals, we recommend shielded, twisted-pair wire. When shielded wire is used, ground the shield as near to the unit as possible, but NOT to its case.

The 4-20 or 10-50 mA input signal comes from a process operation. The power requirements for the SCX differ depending on the input/output configura-

tion of the unit. When preparing to place the SCX into service, it is important for you to know the voltage available in the process, and what the voltage drop is of the SCX. You must also factor in the voltage drop of the device the SCX outputs to. Refer to table 1 for the power requirements of the SCX.

Figure 5 is a typical hookup diagram for the SCX when it is used to isolate a 2-wire process loop signal. Figure 6 is a typical hookup for isolating signal from a 4-wire instrument.

DIN Unit Test Points. The DIN-style Housing has two test points, marked "+T" and "-T", on the front panel. These test points can be used to monitor the unit's output without affecting the process loop. To use these test points, connect a dc voltmeter across them and convert the meter reading using this equation: $0.1 \text{ Vdc} = 10 \text{ mA}$.

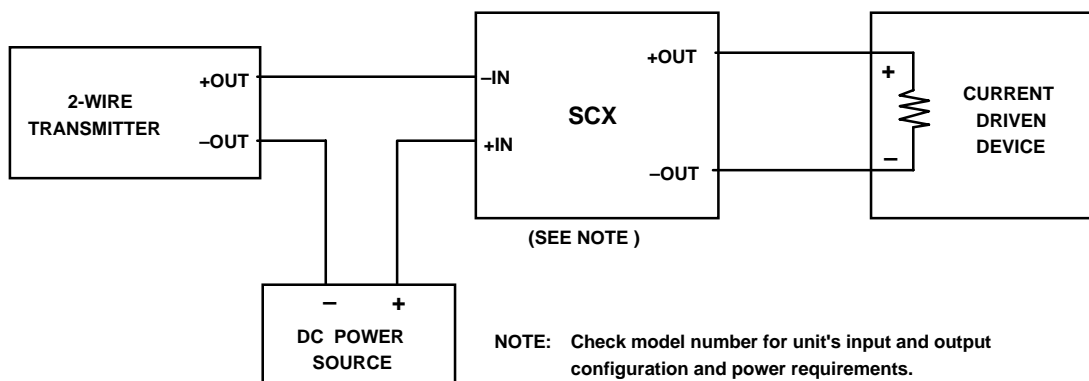

Figure 5. Typical Installation Hookup for a 2-wire Loop Input

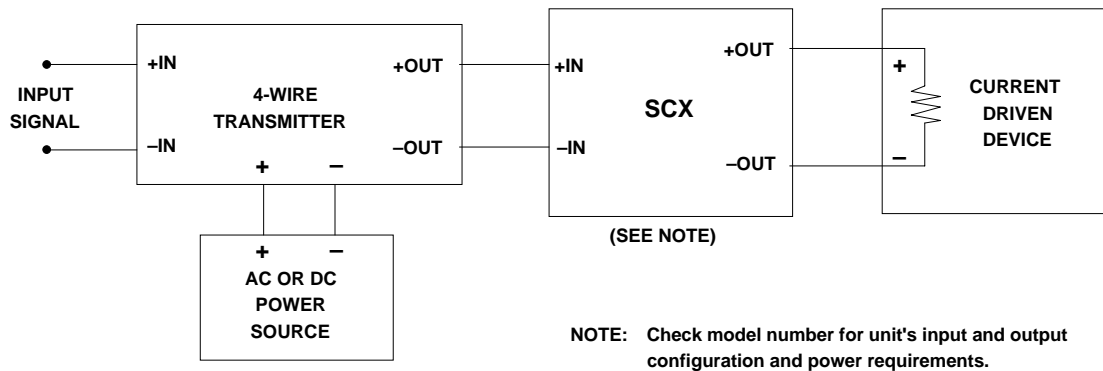

Figure 6. Typical Installation Hookup Using a 4-wire Input Device

Maintenance

Once the SCX is properly calibrated and installed, it will operate reliably for extended periods of time. Routine maintenance of the SCX is limited to keeping the unit clean and ensuring terminal connections are secure and free of oxidation. We recommend that you visually inspect the unit at least once every six months to ensure its physical condition is acceptable.

Periodically, you may wish to check the performance of the SCX to ensure that it is operating within the desired parameters. To check its operational performance, take the unit off line and set it up for a bench check as described in the Calibration Section

of this manual. Perform the calibration procedures contained therein to verify the operating condition of the unit.

The schedule for in-service bench checks depends on your facility's maintenance practices and on the unit's performance. We recommend that you bench check the SCX approximately once a year. But, if there is no indication of variation in performance, you may elect to let the SCX remain on-line for longer periods.

If an operational problem arises with the SCX, contact Moore Industries' Customer Service Department at 1-800-999-2900 or your local Sales Representative for assistance. To return a unit, follow the instructions on the back cover of this manual.

Warranty Disclaimer

Moore Industries ("The Company") makes no express, implied or statutory warranties (including any warranty of merchantability or of fitness for a particular purpose) with respect to any goods or services sold by the company. The company disclaims all warranties arising from any course of dealing or trade usage, and any buyer of goods or services from the company acknowledges that there are no warranties implied by custom or usage in the trade of the buyer and of the company, and that any prior dealings of the buyer with the company do not imply that the company warrants the goods or services in any way.

Any buyer of goods or services from the company agrees with the company that the sole and exclusive remedies for breach of any warranty concerning the goods or services shall be for the company, at its option, to repair or replace the goods or services or refund the purchase price. The company shall in no event be liable for any consequential or incidental damages even if the company fails in any attempt to remedy defects in the goods or services, but in such case the buyer shall be entitled to no more than a refund of all monies paid to the company by the buyer for purchase of the goods or services.

Any cause of action for breach of any warranty by the company shall be barred unless the company receives from the buyer a written notice of the alleged defect or breach within ten days from the earliest date on which the buyer could reasonably have discovered the alleged defect or breach, and no action for the breach of any warranty shall be commenced by the buyer any later than twelve months from the earliest date on which the buyer could reasonably have discovered the alleged defect or breach.

Return Policy

For a period of thirty-six (36) months from the date of shipment, and under normal conditions of use and service, Moore Industries ("The Company") will at its option replace, repair or refund the purchase price for any of its manufactured products found, upon return to the Company (transportation charges prepaid and otherwise in accordance with the return procedures established by The Company), to be defective in material or workmanship. This policy extends to the original Buyer only and not to Buyer's customers or the users of Buyer's products, unless Buyer is an engineering contractor in which case the policy shall extend to Buyer's immediate customer only. This policy shall not apply if the product has been subject to alteration, misuse, accident, neglect or improper application, installation, or operation. THE COMPANY SHALL IN NO EVENT BE LIABLE FOR ANY INCIDENTAL OR CONSEQUENTIAL DAMAGES.

To return equipment to Moore Industries for repair, follow these four steps:

1. Call Moore Industries and request a Returned Material Authorization (RMA) number.

Warranty Repair –

If you are unsure if your unit is still under warranty, we can use the unit's serial number to verify the warranty status for you over the phone. Be sure to include the RMA number on all documentation.

Non-Warranty Repair –

If your unit is out of warranty, be prepared to give us a Purchase Order number when you call. In most cases, we will be able to quote you the repair costs at that time. The repair price you are quoted will be a "Not To Exceed" price, which means that the actual repair costs may be less than the quote. Be sure to include the RMA number on all documentation.

2. Provide us with the following documentation:
 - a) A note listing the symptoms that indicate the unit needs repair
 - b) Complete shipping information for return of the equipment after repair
 - c) The name and phone number of the person to contact if questions arise at the factory
3. Use sufficient packing material and carefully pack the equipment in a sturdy shipping container.
4. Ship the equipment to the Moore Industries location nearest you.

The returned equipment will be inspected and tested at the factory. A Moore Industries representative will contact the person designated on your documentation if more information is needed. The repaired equipment, or its replacement, will be returned to you in accordance with the shipping instructions furnished in your documentation.



Demand Moore Reliability • www.miinet.com

United States • info@miinet.com	China • sales@mooreind.sh.cn
Tel: (818) 894-7111 • FAX: (818) 891-2816	Tel: 86-21-62491499 • FAX: 86-21-62490635
Australia • sales@mooreind.com.au	BeNeLux • info@mooreind.eu
Tel: (02) 8536-7200 • FAX: (02) 9525-7296	United Kingdom • sales@mooreind.com
	Tel: 01293 514488 • FAX: 01293 536852